

Installation Requirements

Slayer Espresso Single Group

Counter

- Width: 18.5 in / 47 cm (foot-to-foot)
Width: 22.2 in / 56.4 cm (incl. handles)
- Depth: 23 in / 58 cm
- Height: 15.3 in / 38.8 cm (incl. handles)
- Weight: 110 lbs / 50 kg (tanks filled)
Measurements do not include overhanging components: portafilters.

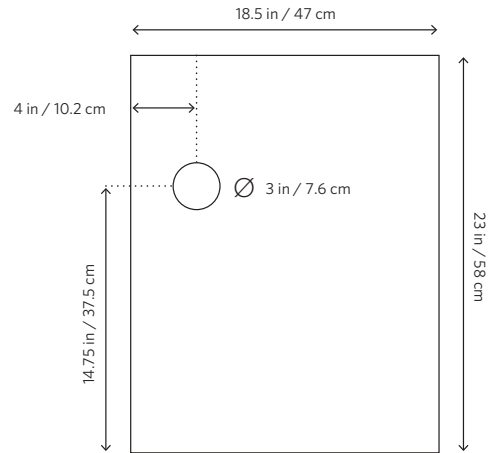

Water

- 3/8-inch BSP dedicated cold water line with shutoff valve (in North America, 3/8-inch compression fitting is included)
- Required incoming water pressure: 3 Bar min, 5 Bar max
- Water hardness cannot exceed 50ppm, otherwise a water softener is needed

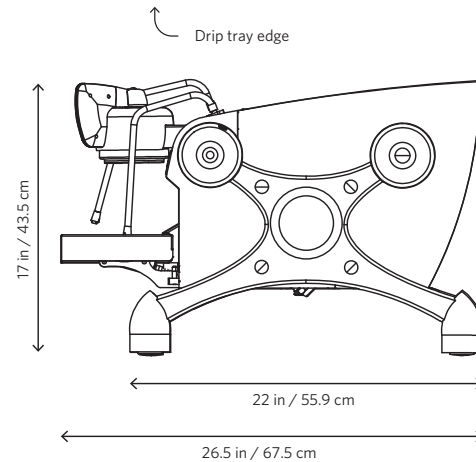

Power

- Single Phase: 120 volts, 50/60 hz, 12 a, 1.5 kW
 - Standard grounded plug end included
 - Receptacle: Nema 5-15
- OR
- Single Phase: 220—240 volts, 50/60 hz, 9a, 2.1—2.4 kW
 - Receptacle: Nema 6-15

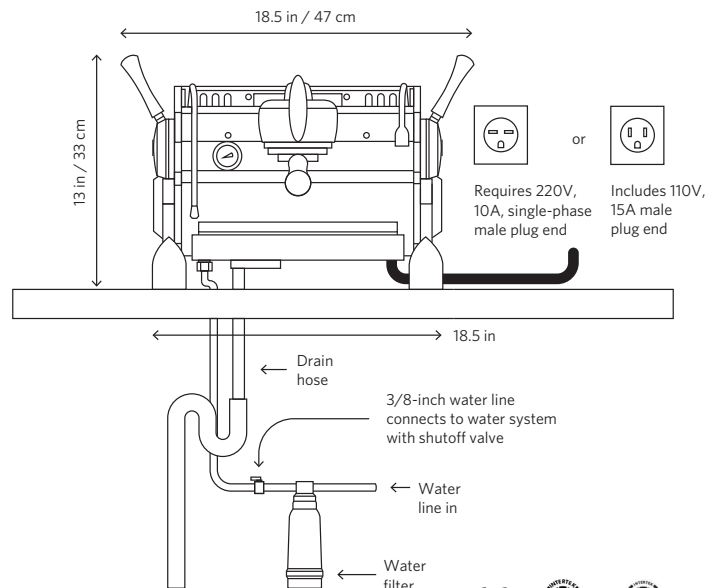

Drain

- Open gravity drain located within 4 feet / 1.2 meters of the machine.
- Ensure drain line is always sloping downwards
- Drain hose: 7/8 inch outside diameter, 5/8 inch inside diameter (2.2 cm outside diameter, 1.6 cm inside diameter).

SLAYER
espresso machines

